

Portofino 52





EXTERIOR AND INTERIOR DESIGN

S A T U R A
STUDIO

ROMA

NAVAL ARCHITECTURE

zer013
NAVAL DESIGN & CONSULTING

MILANO

SHIPYARD

SHIPYARD
PORTOFINO

DUBAI

Specifics



GENERAL SPECIFICATION

LENGTH OVERALL	16,9 M / 55 FT
LENGTH WATERLINE	15,6 M / 51 FT
BEAM OVERALL	8,6 M / 28 FT
DRAUGHT	0,7 M / 2,3 FT
AIR DROUGHT (WITHOUT ANTENNA)	28,1M / 92 FT
LIGHT DISPLACEMENT	18500 KG / 40785 LB
PAYLOAD CAPACITY	12 PASSENGERS / 1080 KG
ENGINE	2 X YANMAR 4JH80 (80HP)
FUEL TANK	2 X 600 L / 158 US GAL
FRESH WATER TANK	2 X 400 L / 105 US GAL
BLACK WATER TANK	2 X 220 L / 58 US GAL
GRAY WATER TANK	2 X 260 L / 68 US GAL
CLASSIFICATION	A
CABINS	3-4-5 CABINS

RIGGING AND SAILS

MAST	DECK-STEPPED ANODIZED ALUMINIUM MAST, 2 LEVELS OF SPREADERS
MAIN SAIL AREA	107 M2 / 1152 SQFT
JIB AREA	55 M2 / 592 SQFT
SELF TACKING JIB	YES
CODE ZERO AREA	160 M2 / 1722 SQFT
GENNAKER AREA	140 M2 / 1507 SQFT

CONSTRUCTION

HULL	ALUMINIUM 5083
SUPERSTRUCTURE	ALUMINIUM 5083
SYSTEM VOLTAGE	48/24
BATTERY BANK	40KW LITHIUM 48 V

Layout

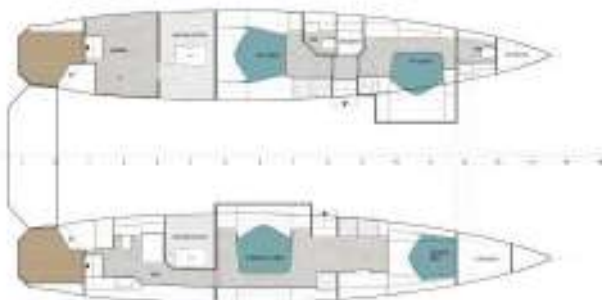
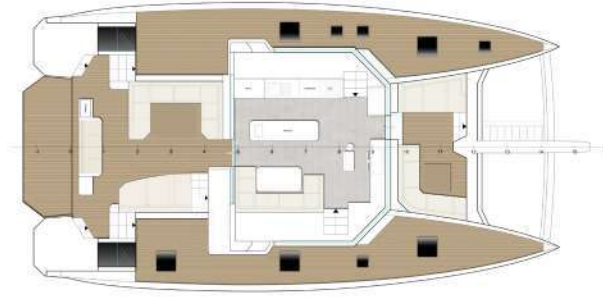
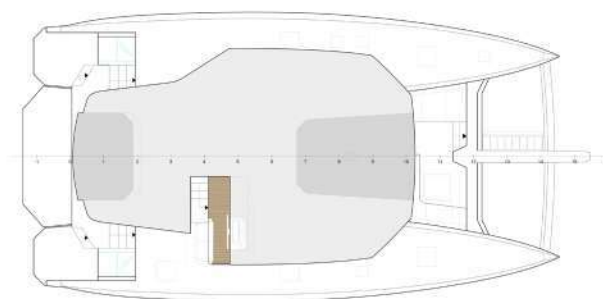
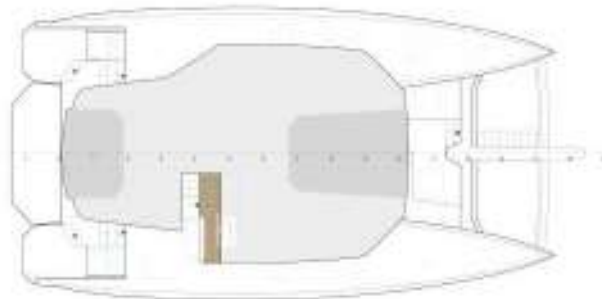
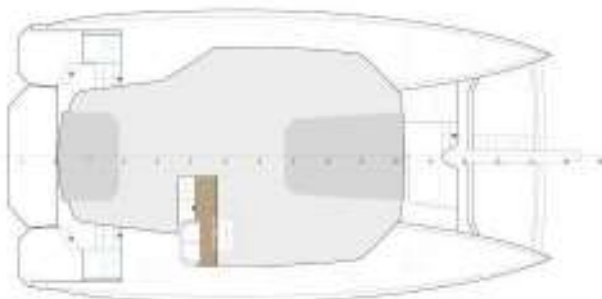

3 CABINS

4 CABINS

5 CABINS



Exterior

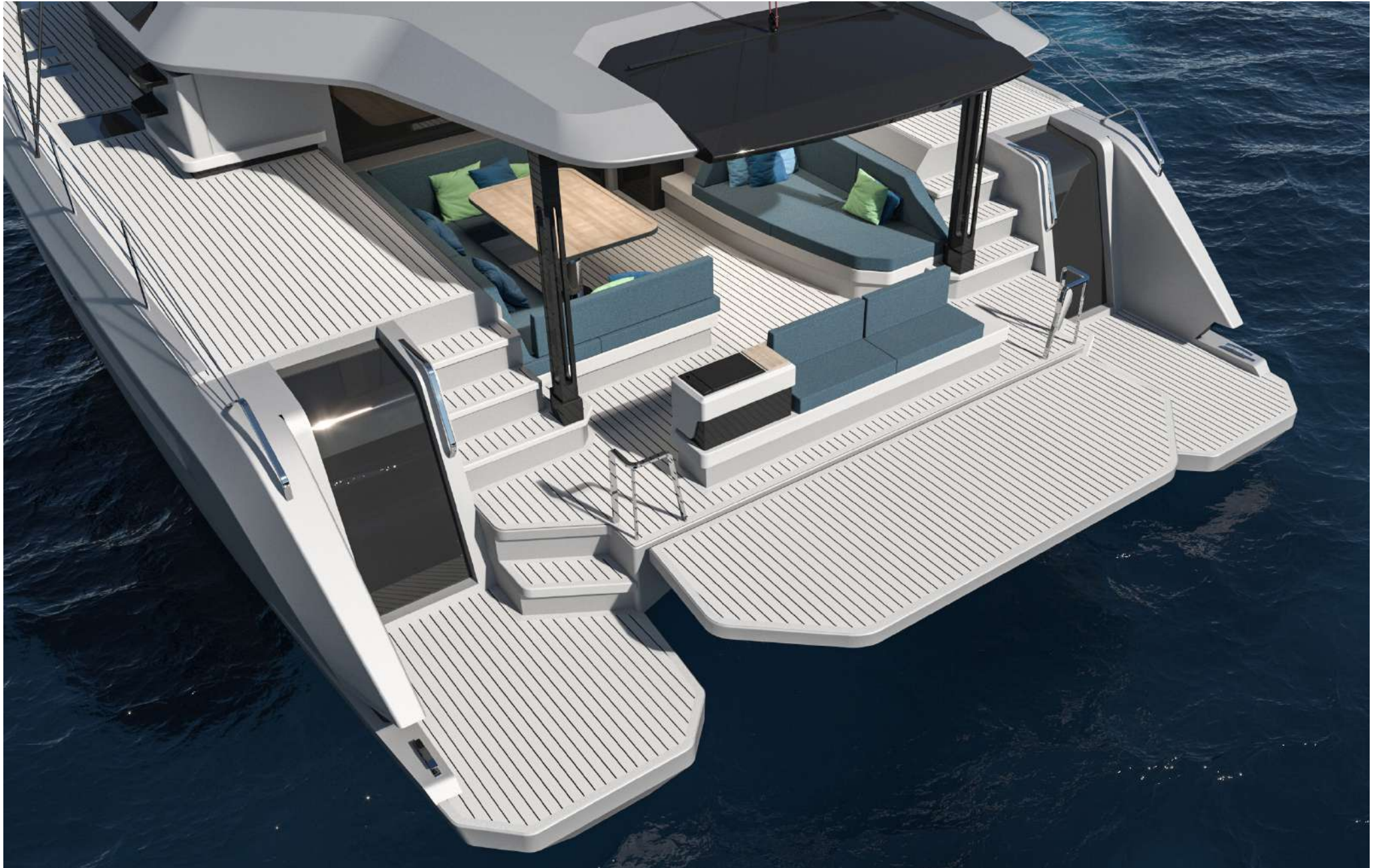

Exterior



Exterior

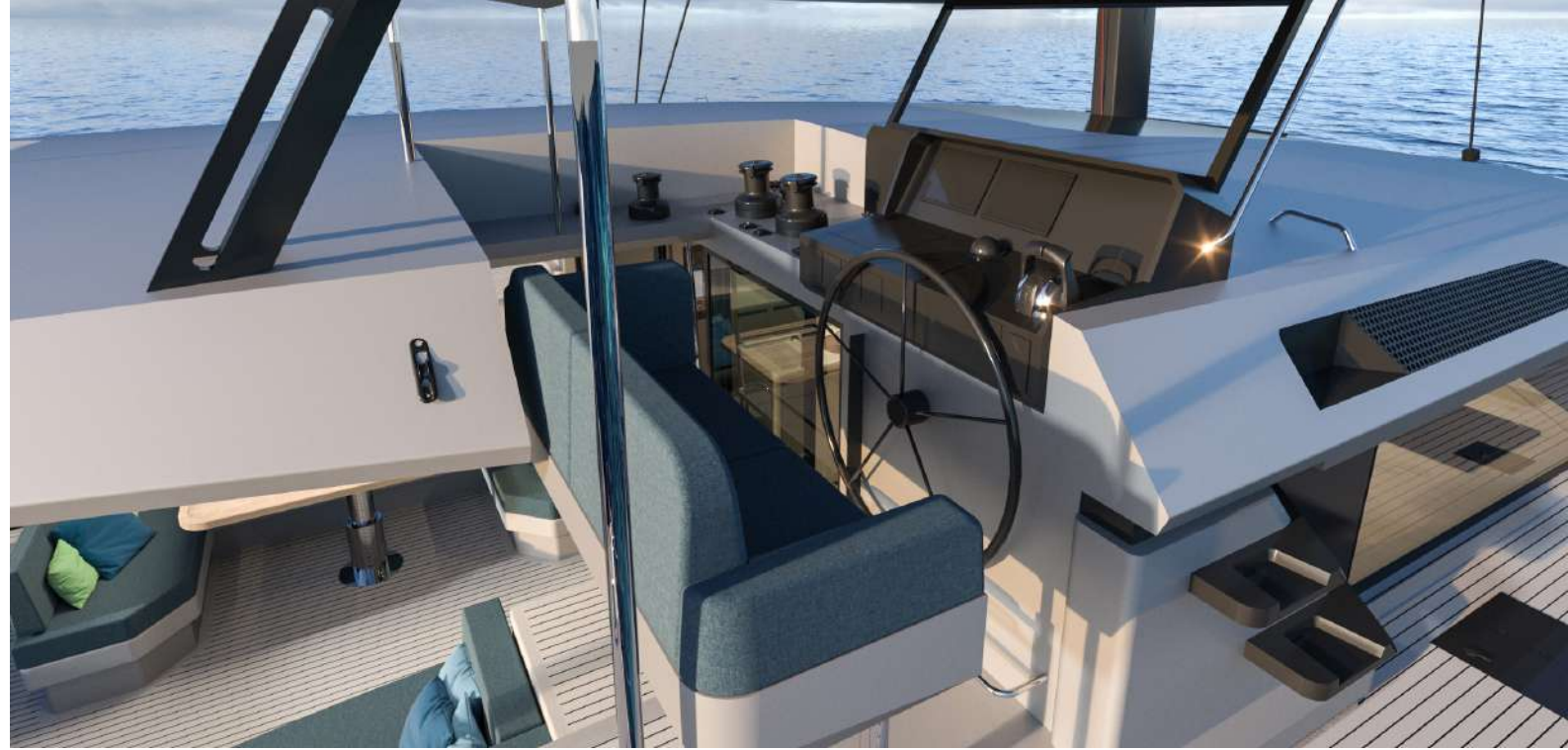

Interiors



MAIN SALON

Interiors



OWNER'S CABIN

Keels mechanism

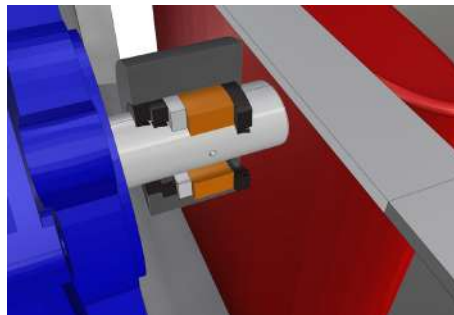
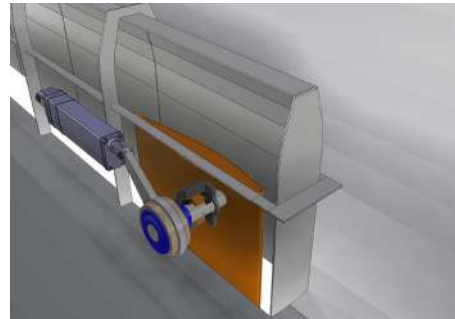
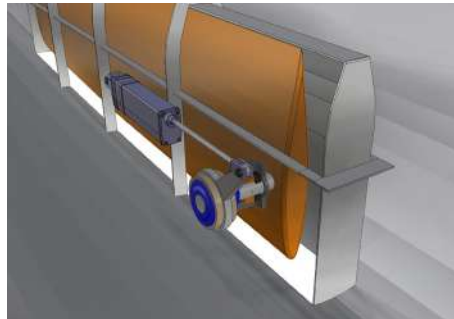
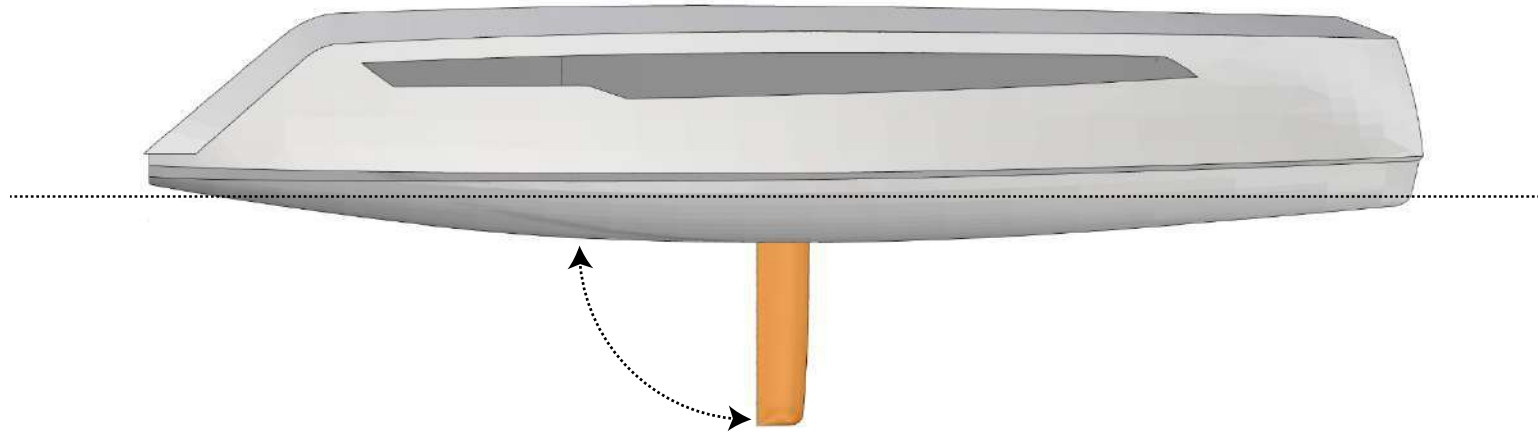

With the keels inside the draft of the boat is less than 70 cm (2 feet) the rudders are also retractable.

The keels are operated with 2 separated 48 Volt DC electric actuators a manual system can be used in case of blackout or any other failure.

The torque limiter will prevent damage in the keels and in the hull by disconnecting the shaft in case of impact.



PortofinoMarineServices L.L.C.

Al Jadaf 85 - Dubai, United Arab Emirates
www.portofinomarineservice.com
info@portofinomarineservice.com
Phone - 00971506946034



ITALIAN DESIGN BUILT IN DUBAI